

[Next](#) [Up](#) [Previous](#) [Index](#)**Next:** [18. Telephone and Data](#)**Up:** [Information Technology - Inside](#) **Previous:** [Try These Exercises](#)**Home:** [Contents: Information Technology - Inside and Outside](#)

VII. Networks and the Internet

Maybe I've a reason to believe
We all will be received

Paul Simon, Graceland, Graceland

In this part of the book we come to the home stretch: the organization and operation of networks of interconnected computers and information appliances. We will begin by comparing and contrasting telephone and data networks of the type that predominate today: the Public Switched telephone System and the Internet.

To understand all the issues involved in the convergence of all communication systems toward a single universal system, we will have to expose a number of the details of the behaviors of these networks. One of the revelations will be the nature of the secret codes that are used to insure the security of everything from telephone conversations to financial transactions on the Internet.

Finally, with the rest of the book behind us and its lessons learned, we can discuss the technological problems, future solutions, cost of and advantages of the convergence of telephone and Internet.

-
- [18. Telephone and Data Communications Networks](#)
 - [18.1 Introduction](#)
 - [18.1.1 Circuit and Packet-Based Networks](#)
 - [18.2 Circuit-Based Networks](#)
 - [18.2.1 Telephone Circuits Are More than Just Wire](#)
 - [18.2.2 Public Switched Telephone Network Digital Services](#)
 - [18.2.3 An Example of a Digital Transmission System: The T1 Carrier](#)
 - [18.2.4 Integrated Services Digital Network \(ISDN\)](#)
 - [18.3 The Packet-Switched Connection](#)
 - [18.3.1 X.25 and the Virtual Circuit](#)
 - [18.3.2 Wider Bandwidth Data Transmission: Frame Relay](#)
 - [18.3.3 Asynchronous Transfer Mode](#)
 - [Summary](#)

- [Try These Exercises](#)
- [19. The Local Area Network](#)
 - [19.1 Introduction](#)
 - [19.2 Datagram Packet Switching](#)
 - [19.3 The Ethernet](#)
 - [19.3.1 The Ethernet Datagram](#)
 - [19.3.2 Datagram Transmission and Delivery](#)
 - [19.3.3 Collision Detection Multiple Access](#)
 - [Summary](#)
 - [Try These Exercises](#)
- [20. Organization of the Internet](#)
 - [20.1 Introduction](#)
 - [20.2 How Would You Organize Universal Mail Delivery?](#)
 - [20.2.1 The Internet: Three Addressing Schemes](#)
 - [20.2.2 Tracing a Route](#)
 - [20.3 What Makes up the Backbone of the Internet?](#)
 - [Summary](#)
 - [Try These Exercises](#)
- [21. Electronic Commerce and Information Security](#)
 - [21.1 Introduction](#)
 - [21.2 Threats to Information Security](#)
 - [21.3 Security Services](#)
 - [21.4 Data Security and Cryptosystems](#)
 - [21.4.1 An Example of an Unconditionally Secure Code](#)
 - [21.5 Computationally Secure Symmetric Key Cryptography](#)
 - [21.5.1 Commonly Encountered Symmetric Codes](#)
 - [21.6 Public Key Cryptography](#)
 - [21.6.1 Public Key Standards](#)
 - [21.7 Digital Signatures](#)
 - [21.8 Digital Certificates](#)
 - [21.9 Electronic Commerce](#)
 - [Summary](#)
 - [Try These Exercises](#)

- [22. Voice over IP and the Convergence](#)
 - [22.1 Introduction](#)
 - [22.2 Circuit-Switched Telephone Systems](#)
 - [22.2.1 Sampling and Digitizing Telephone Voices](#)
 - [22.2.2 Moving Digital Voice in a Circuit-Based Network](#)
 - [22.3 The IP Packet Connection](#)
 - [22.3.1 The Drive to IP Networks](#)
 - [22.3.2 To IP or not to IP](#)
 - [22.3.3 Conveying Packets](#)
 - [22.3.4 Moving Voice with Packets](#)
 - [22.4 How to and Why Move to VoIP?](#)
 - [22.4.1 How Do You Make VoIP Work?](#)
 - [22.4.1.1 Reducing Routing Delays](#)
 - [22.4.1.2 Reducing Effects of Congestion](#)
 - [22.4.2 How VoIP Is Already Being Applied](#)
 - [22.4.2.1 Software Only VoIP](#)
 - [22.4.2.2 VoIP Gateways and Intranets](#)
 - [22.4.2.3 VoIP in the LAN](#)
 - [22.4.3 The Driving Force behind VoIP](#)
 - [Try These Exercises](#)

[Next](#) [Up](#) [Previous](#) [Index](#)

Next: [18. Telephone and Data](#)**Up:** [Information Technology - Inside](#) **Previous:** [Try These Exercises](#)*Information Technology - Inside and Outside*

[Next](#) [Up](#) [Previous](#) [Index](#)

Next: [18.1 Introduction](#)**Up:** [VII. Networks and the](#) **Previous:** [VII. Networks and the](#) **Home:** [Contents: Information Technology - Inside and Outside](#)

18. Telephone and Data Communications Networks

The essence of communications is the ability for any two or more terminals to send and receive data among themselves at any time, regardless of their locations. This requires a communications network. In this chapter you will learn about:

- the two fundamental types of networks: circuit-based and packet-based networks;
- the means by which circuit-based networks establish a path between two end points for communication;
- the public switched telephone network (PSTN);
- digital transmission systems (including T1) used on the PSTN;
- the ways in which packet-based networks get data from transmitter to receiver without a dedicated path between the two terminals; and
- some types of data communications protocols, including Frame Relay and asynchronous Transfer mode.

-
- [18.1 Introduction](#)
 - [18.1.1 Circuit and Packet-Based Networks](#)
 - [18.2 Circuit-Based Networks](#)
 - [18.2.1 Telephone Circuits Are More than Just Wire](#)
 - [18.2.2 Public Switched Telephone Network Digital Services](#)
 - [18.2.3 An Example of a Digital Transmission System: The T1 Carrier](#)
 - [18.2.4 Integrated Services Digital Network \(ISDN\)](#)
 - [18.3 The Packet-Switched Connection](#)
 - [18.3.1 X.25 and the Virtual Circuit](#)
 - [18.3.2 Wider Bandwidth Data Transmission: Frame Relay](#)
 - [18.3.3 Asynchronous Transfer Mode](#)
 - [Summary](#)
 - [Try These Exercises](#)
-

[Next](#) [Up](#) [Previous](#) [Index](#)

Next: [18.1 Introduction](#) **Up:** [VII. Networks and the](#) **Previous:** [VII. Networks and the](#) *Information Technology - Inside and Outside*

Next: [18.1.1 Circuit and Packet-Based](#) **Up:** [18. Telephone and Data](#) **Previous:** [18. Telephone and Data](#) **Home:** [Contents: Information Technology - Inside and Outside](#)

18.1 Introduction

Any discussion of networks should begin with an explanation of their basic function. The function of a network is to allow two or more end points to communicate information. This definition is very broad and very incomplete. It would logically bring up the following questions:

- What sort of information is to be communicated?
- Is the communication to be one-way or two-way?
- Must the communication be in real time?
- How many simultaneous users must the network handle?
- Are all users to be connected in pairs (like a normal telephone call) or in some other arrangement?
- Are the user-user connections permanent, or do they change frequently?
- What is the typical period of time that a connection is maintained?

The answers to these questions help define the design and physical arrangement of the network. To demonstrate this, we will examine a few cases with which almost everyone has familiarity.

Most of the existing telephone network was designed to provide a communications connection which is:

Two-Way:

Each party can speak to the other; that is, this is a system meant for conversation and not presentation or publication.

Real-Time:

A delay in excess of about 1/3 of a second is disrupting to conversations, as it is a large enough a time period to be confused with vocal gestures (pause, doubt, surprise).

Pair wise:

The conversation is an exchange between two people and not an open forum for anyone to join.

Circuit Switched Connection:

Voice connections are set up and taken down frequently under control of the user (by dialing a number) as opposed to being permanent (in which case we would need a telephone in our house for each party to whom we ever intended to speak).

The telephone network is used today for many purposes other than voice conversations, of course, but these applications are supported with varying degrees of efficiency that may fall far from the best possible, with specifically engineered networks having attributes that more closely match the needs of that type of communication.

How different can these needs be? Let's now take the case of a cable television network. Most of the cable television network was designed to provide a communications connection which is:

One-Way:

The television programming provider sends its video product to your home and not vice versa.

Not Real-Time:

As a viewer you don't really care or notice if the program you are watching is 10 seconds late or more. Because the communication is not two-way, there is no sense of delay, and hence the provider can use slow channels (satellites) or even manually mounted tape recordings to provide the video feed.

One-to-Many:

The provider does not individually package and transmit TV shows to each user. A single launch of information is made of all the TV shows to all users. Users, of course, can independently select which information in the information stream to show on their screens (and with some modern TV sets, several of these can be watched at the same time).

Permanent Connection:

The connections between the provider and the users are not switched or directed. As noted above, the same information is transmitted on one network to all viewers. When the viewers switch channels, they are only selecting what part of the information to view and are not altering what is being sent.

-
- [18.1.1 Circuit and Packet-Based Networks](#)

Next	Up	Previous	Index
----------------------	--------------------	--------------------------	-----------------------

Next: [18.1.1 Circuit and Packet-Based](#)**Up:** [18. Telephone and Data](#) **Previous:** [18. Telephone and Data](#)*Information Technology - Inside and Outside*

[Next](#) [Up](#) [Previous](#) [Index](#)

Next: [18.2 Circuit-Based Networks](#) **Up:** [18.1 Introduction](#) **Previous:** [18.1 Introduction](#) **Home:** [Contents: Information Technology - Inside and Outside](#)

18.1.1 Circuit and Packet-Based Networks

There are many means by which a network can be implemented, with large variations in operation such as in the choice of the type of signal used (electrical, radio, light, etc.). A very significant difference, determined by the information engineering involved in its design, is whether the network is said to be circuit or packet-based.

Short definitions of these two types of networks are:

- *Circuit-based networks* are those in which a path is maintained between the users for the duration of the call; and
- *Packet-based networks* are those in which individually addressed packets of information are sent into a communications system, and are individually forwarded until they reach the recipient.

The circuit-based network with which the reader might be best acquainted is the telephone system. After a number has been dialed, a circuit is established. That is, a path has been created between your telephone and that of the person you called. You can think of the telephone circuit and any other circuit-based network connection as a hollow tube running between two end points. Anything you drop in one end of the tube will come out the other end (for example, your voice in the case of the telephone network). If you want to communicate with a second person, you need to establish a second circuit. The destination of your message is determined by the tube into which you drop the message. In the case of cable television networks (which are circuit-based) the provider drops the same messages into all the tubes.

The packet-based network with which the reader is probably most acquainted is the postal system. To send a packet of information (a letter) to someone, you must put an address on an envelope. Then, you drop the letter into a mailbox. This mailbox no longer acts like a tube following a single path to the destination. In fact, you can drop many messages with different addresses into the same mailbox and they will each be directed to the correct recipient, in stark contrast to the telephone example above. In fact, not only do you not need a separate box for each possible recipient, you can actually use any mailbox you find on any street to send the same piece of mail.

This apparently simple division is often complicated and confused, since many technologies have been implemented that blur the line in an effort to capture the advantages inherent to both types of networks in a single system. More confusion derives from application of simple rules to an endpoint of the communication system without a full understanding of the complete underlying network technology. For example, suppose we placed a special machine over the opening of a mailbox that has three slots. We can label these three slots with names of destinations (say, specific addresses in New York City, Chicago, and Houston). Our machine prints the address associated with a slot onto an envelope when it is dropped into that slot.

To the user of this system, it appears that the network is circuit-based because separate and *dedicated* (meaning one slot sends messages to one and only one recipient) paths have obviously been created. In reality, a packet-based infrastructure (the post office) has been made to appear to provide a circuit-based service.

In the remainder of this chapter we will treat the circuit-based approach in greater depth, and discuss several of the circuit-based systems that are available today for the network service customer.

Next	Up	Previous	Index
----------------------	--------------------	--------------------------	-----------------------

Next: [18.2 Circuit-Based Networks](#) **Up:** [18.1 Introduction](#) **Previous:** [18.1 Introduction](#) *Information Technology - Inside and Outside*

[Next](#) [Up](#) [Previous](#) [Index](#)

Next: [18.2.1 Telephone Circuits Are](#) **Up:** [18. Telephone and Data](#) **Previous:** [18.1.1 Circuit and Packet-Based](#) **Home:** [Contents: Information Technology - Inside and Outside](#)

18.2 Circuit-Based Networks

The term *circuit* originally referred to an unbroken pair of copper wires that connected one endpoint in a communications connection to the other endpoint. Thus a circuit here refers to the same kind of electrical circuit we associate with a light bulb, as with, and the wires that connect them and a power source. When we flick a switch, we expect that only the light to which it is connected (and always has been connected) will turn on and off. Thus the circuit represents one of the simplest means of establishing electrical communications between two points.

How do circuits for communications come into being? A user might lay, or buy/rent an existing cable between the two points. Obviously, the two endpoint users in this case are the only users of the circuit. Thus the circuit formed by the cable provides the source user with a dedicated (unshared, unmovable), permanent (always available), and invariant (constant bandwidth) connection to the destination user. Systems that provide these attributes are now considered circuit-based systems whether or not they are based on wire-cable, and whether or not they are truly a single piece of cable or a vast network of electronics that simply provides the same interface and capability.

Originally such circuit connections were provided by physically laying a cable between every source and destination (the telegraph network and very early telephone systems). This is an extremely costly system when a high level of connectivity is desired. If N parties want to each be able to connect to any other party in the group, then $N \times (N - 1)/2$ wires need to be laid. So, the number of wires need is proportional to approximately the square of the number of parties in the group.

Furthermore, the cost of this process goes beyond the cost of the cable and the labor for placing it. The true cost must include the time and money associated with acquiring the rights to place the cable on a right-of-way which may be owned by many individuals, corporations, and municipalities. Thus, a solution is sought that minimizes the number of wires needed while still allowing anyone to connect to anyone else.

The next step in the evolution of this system took place with the recognition that efficiencies could be gained by enabling a small number of existing wires to be reconnected as the desired user pairs changed. This led to the development of telephone central offices so that cables were laid from all potential users to the central office, rather than from user to user.

At first, telephone operators manually made the electrical connections by moving small connecting cables between points on a switch panel that connected to all the end users. To make a call, you rang the operator and asked him or her to make a connection between you and the desired party.

That system was soon replaced by the telephone dial mechanism (originally rotary and now pushbutton) and automatic switching system that allowed the user to make the connection without an operator's assistance. In a small town, a system in which all homes and businesses were connected by cables to a single central office was sufficient to connect all users to all other possible users.

In larger cities, many central offices were necessary because the distance between users at the outskirts and a centrally located office were such that the lengths of connecting cable became prohibitively costly, and effects of attenuation and dispersion of signals mentioned earlier in this book reduced the quality of the voices that were received below acceptable levels. Thus many central offices (called exchanges) needed to be placed in the city, serving smaller groups of parties.

But, it was altogether likely that within one city, people connected to different exchanges needed to talk to one another. So, these central offices were connected with cables that were similar or identical to those that ran to the users. These cables are called *trunks* to distinguish them from the user cables, which are called *loops*.

In time this system was expanded further, introducing a hierarchy of telephone switching offices that enable any two telephones in the world to communicate by putting together a single circuit formed of two loops (one at each customer end), and any number of trunks between intermediate central offices. This switching function will be discussed in more detail in the next section.

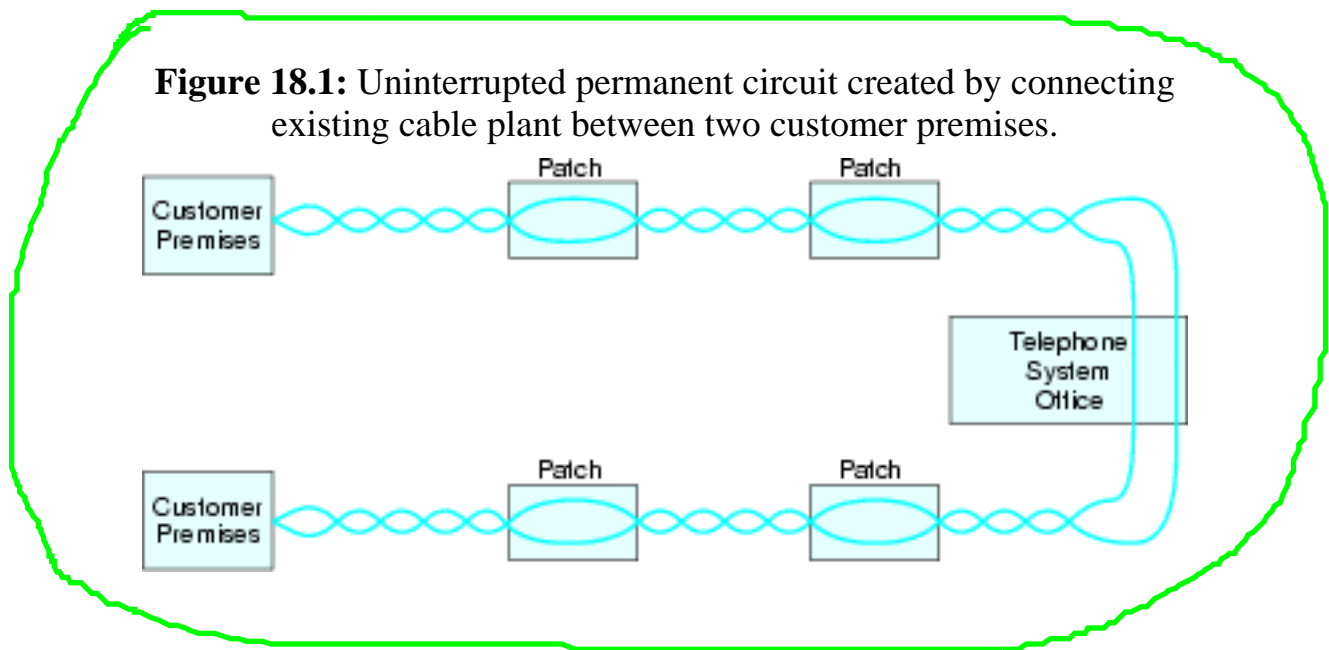

- [18.2.1 Telephone Circuits Are More than Just Wire](#)
- [18.2.2 Public Switched Telephone Network Digital Services](#)
- [18.2.3 An Example of a Digital Transmission System: The T1 Carrier](#)
- [18.2.4 Integrated Services Digital Network \(ISDN\)](#)

[Next](#) [Up](#) [Previous](#) [Index](#)

Next: [18.2.1 Telephone Circuits Are](#)**Up:** [18. Telephone and Data](#) **Previous:** [18.1.1 Circuit and Packet-Based](#)*Information Technology - Inside and Outside*

[Next](#)
[Up](#)
[Previous](#)
[Index](#)

Next: [18.2.2 Public Switched Telephone](#)
Up: [18.2 Circuit-Based Networks](#)
Previous: [18.2 Circuit-Based Networks](#)
Home: [Contents: Information Technology - Inside and Outside](#)

18.2.1 Telephone Circuits Are More than Just Wire

The advent of widespread telephony and the fact that cabling rights were negotiated on a wholesale scale for the popular telephone service, made the telephone companies a source of *circuit services* for purposes other than telephone calls. Thus, a circuit customer can rent a permanent circuit between two points directly from the telephone companies involved along the source-to-destination path. The telephone company makes use of its extensive and excessive (beyond its current telephony needs) in-place cable resources to patch together a continuous circuit from pieces of cable already in place by connecting these pieces at telephone switching offices where they come together. While composed of many pieces of cable, this configuration is still essentially a single unprocessed signal conduit in form (Figure 18.1).

However, to deliver better voice transmission services, the telephone system itself does not simply use the raw capability of wire cables to move electrical signals representing human voices over long distances. As mentioned above, attenuation and dispersion grow with increasing cable length. A sufficiently long cable would so much distort a voice as to make it unrecognizable.

To extend the transmission distance achievable with cable circuits, the telephone companies insert special electronic circuits called repeaters between segments of a long cable path. These repeaters receive and retransmit the signals present on the circuit lines at periodic intervals to strengthen and restore them. Thus, while no longer a simple copper-wire cable circuit, this system acts exactly like a low signal-loss single-cable circuit (Figure 18.2).

Figure 18.2: Permanent circuit using repeaters to achieve greater bandwidth and reduced attenuation of large signaling distances.

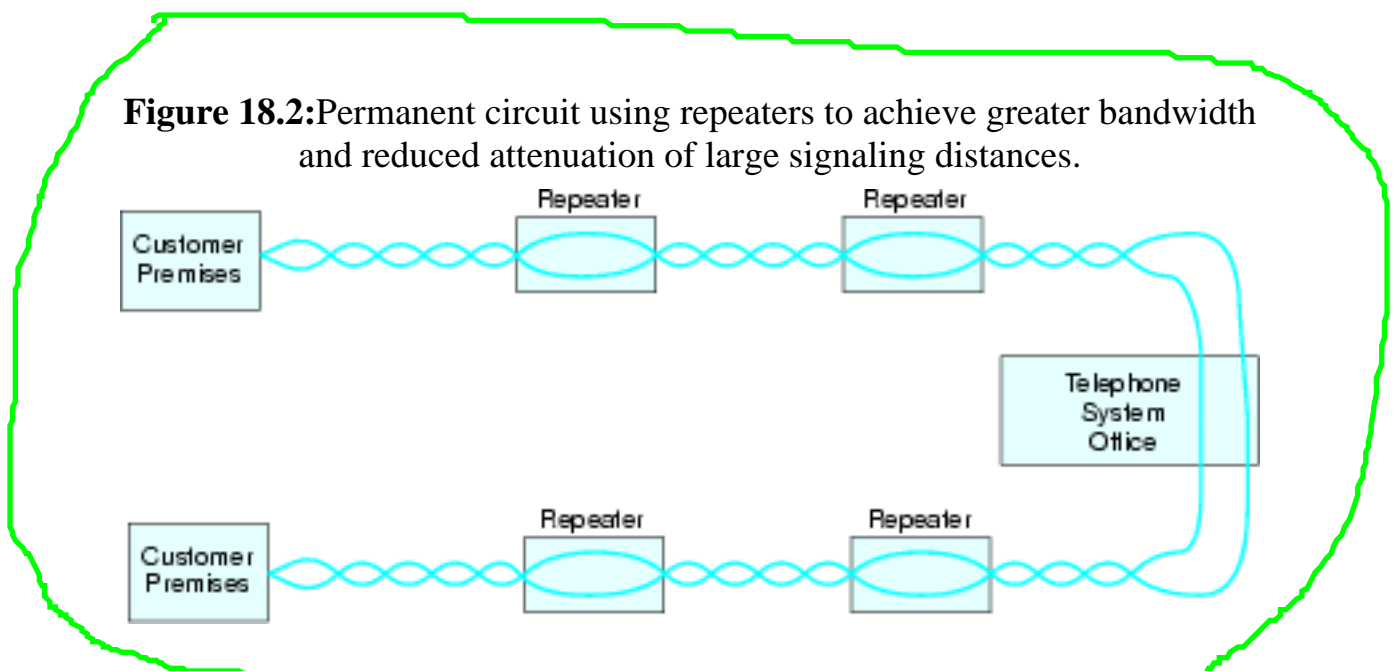

Even though the telephone circuit is now more complicated than a simple loop of wire, it can still be used as a conduit of signals other than those voice signals created by a telephone set. Thus, a system that is designed to carry signals generated by telephone microphones to telephone ear pieces is actually a more general device: a virtual electrical pipe between two places.

The telephone system has continued to evolve due to changes in electronic and photonic (light communications) technology, and at present almost all of the telephone networks beyond the local loop actually make use of digital signals, and hence have a form radically different than the wire cable and repeater system described above. But even in this new form, the concept of the circuit connection may still be applied because the mechanisms in use create a switched, dedicated, fixed-bandwidth path between the users.

[Next](#) [Up](#) [Previous](#) [Index](#)

Next: [18.2.2 Public Switched Telephone](#) **Up:** [18.2 Circuit-Based Networks](#) **Previous:** [18.2 Circuit-Based Networks](#) *Information Technology - Inside and Outside*

[Next](#) [Up](#) [Previous](#) [Index](#)

Next: [18.2.3 An Example of Up: 18.2 Circuit-Based Networks](#) **Previous:** [18.2.1 Telephone Circuits](#)
Are Home: [Contents: Information Technology - Inside and Outside](#)

18.2.2 Public Switched Telephone Network Digital Services

The telephone companies comprise what has commonly been called the **Public Switched Telephone Network, or PSTN**. The PSTN has traditionally been in the business of providing temporary circuit-based connections on demand for voice communications.

It has come to pass many times in the history of business and technology that if a resource is made available with few constricting rules, someone will find new ways to exploit it for their benefit. For example, some users choose to use special devices known as telephone data modems for the transmission of data on analog telephone connections. The modem transforms the data bit stream into a signal that resembles a voice signal sufficiently that it can pass through the system and be recognized by another modem at the other end.

Unfortunately, the limitations imposed by a network designed for the transport of voice information greatly limited the practicality of large-scale, high-speed data transmission. Such applications were technically feasible by using many simultaneously operating *voice-grade* connections, or by obtaining use of the wire cable from the telephone system with all electronics removed or replaced by different electronics better suited to the purpose. Thus, while possible, the economics of the situation worked against direct high-speed data links.

The economics, however, began to change as dramatic drops in the price of digital electronics made high-speed long-distance digital interconnection less costly than analog circuit lines. Today, for example, fiber-optic lines connect many distant points in the PSTN with digital signaling speeds of 622 Mbps from end to end. Thus, very high bit rate digital circuit channels can be sliced out of the available connection bit stream for resale to digital services subscribers. In effect, the PSTN merely dedicates some bit stream locations that would have served some number of telephone conversations to the transport of the digital data for customers of digital data transport services.

Thus users may now exploit the telephone system for transport of data at certain digital data speeds and formats that conform to PSTN standard interfaces. The formats and speeds are rather specific, as the PSTN needs to be able to absorb the subscriber's data and to introduce it into the well-organized train of continuously generated bit streams from the thousands of digitized telephone conversations sharing the same transmission system. On the other hand, while the interface is specialized and the connection is certainly in no electrical sense a single circuit any more, the service available to the user still presents all the features of the original circuit:

- On arrangement with the PSTN it can be a permanent circuit.
- It makes a fixed transmission data rate available at all times exclusively for that user.

Suppose a user only has need for transmitting bursts of digital data separated by large periods of non

use, and that furthermore, the user needs to transmit this data not just to one recipient but to a variety of end points depending upon an ever-changing situation. Then we are back to a situation like that created by the user of voice telephone service, except that data rather than voice is being transmitted. In that case, even though the backbone circuits that makeup the telephone system are digital, the PSTN still provides an analog connection on request for use by ordinary telephones. So, our user with variable endpoint digital service needs can make use of the switched nature of the all-digital telephone system.

A customer can contract with the PSTN to provide a switched digital data circuit, which does not provide a permanent connection to a single endpoint, but rather provides a service for data just like the one we use for ordinary phone calls: a telephone number is used to make a connection (call set-up) when it is needed to the desired endpoint and then disconnected (tear-down) when we are finished. The rates associated with this service can be considerably less than that with a permanent circuit because we are only charged for connect time.

The downside to this approach include:

- the time delay involved with call set-up and tear-down;
- the possibility of getting a busy signal;
- the possible higher cost than that of a dedicated circuit if the line is in use much of the time.

As will be shown later in this chapter and in the next chapter, these *downside* are opportunities for other network architectures to address.

[Next](#) [Up](#) [Previous](#) [Index](#)

Next: [18.2.3 An Example of](#)**Up:** [18.2 Circuit-Based Networks](#) **Previous:** [18.2.1 Telephone Circuits](#)
[Are](#)*Information Technology - Inside and Outside*

[Next](#) [Up](#) [Previous](#) [Index](#)

Next: [18.2.4 Integrated Services Digital](#) **Up:** [18.2 Circuit-Based Networks](#) **Previous:** [18.2.2 Public Switched Telephone](#) **Home:** [Contents: Information Technology - Inside and Outside](#)

18.2.3 An Example of a Digital Transmission System: The T1 Carrier

One of the first and most popular digital permanent circuit services sold by the PSTN in North America was the so-called *T1 carrier*. This transmission system was devised originally to transport sets of 24 simultaneous digitized phone conversations over simple pairs of copper wire over distances of up to approximately 50 miles. Repeaters were placed 6,000 feet apart along the path of the cable to regenerate the signal, which otherwise would suffer severe degradation due to cable losses. The overall bit rate of this digital data transmission system is 1.544 Mbps per channel.

It is typical telephone parlance to refer to the format of the digital signal involved in T1 transmission not as a T1 signal, but rather as a DS1 (Digital Services 1) signal, because this same format can be used on essentially any kind of cable. Thus, T1 refers to both the physical medium (the twisted pair cable) and the DS1 format of the digital data being used to move the data on that cable.

The digitized voice telephone signals transmitted by a T1 carrier are represented by 8,000 samples per second quantized to 8 bits per sample. Actually, some of these data bits are "stolen" to provide synchronization information and "signaling" information, which is for routing the data at the various switch points. Also, one additional bit is inserted into the stream for every 192 bits (24 voice channels \times 8bits), which is used to establish overall synchronization of the channels within the stream. Thus, $193 \text{ bits} \times 8000 \text{ samples/sec} = 1.544 \text{ Mbps}$ are transmitted.

Table 18.1: The North American Digital Multiplex Hierarchy

Service Name	Bit Rate	Number of Voice Channels
DS1	1.544 Mbps	24 ch
DS2	6.312 Mbps	96 ch
DS3	44.736 Mbps	672 ch
DS4	274.176 Mbps	4032 ch

As summarized in Table 18.1, a variety of data services, originally conceived as bundles of digital voice data, are available from the PSTN. These services are very much the backbone of long distance Internet services provided by Internet Service Providers (ISPs) such as America Online,

[Compuserve](#), and [Prodigy](#). (The transmission hierarchy is different in Europe, where groups of 30 voice channels rather than 24 are the basis for the hierarchy.)

With the advent of still higher data rate requirements and the means to provide them through fiber-optic transmission media, [new standards for digital data transmission have been devised by the PSTN on a global basis](#). Table [18.2](#) summarizes the North American and European (CCITT) standards for digital transmission over fiber-optic cables.

[Next](#) [Up](#) [Previous](#) [Index](#)

Next: [18.2.4 Integrated Services Digital](#) **Up:** [18.2 Circuit-Based Networks](#) **Previous:** [18.2.2 Public Switched Telephone](#) *Information Technology - Inside and Outside*

[Next](#) [Up](#) [Previous](#) [Index](#)

Next: [18.3 The Packet-Switched Connection](#) **Up:** [18.2 Circuit-Based Networks](#) **Previous:** [18.2.3 An Example of Home: Contents: Information Technology - Inside and Outside](#)

18.2.4 Integrated Services Digital Network (ISDN)

In the late 1980s, the PSTN gave users direct access to a switched digital service. This service, which parallels the regular voice telephone network, became widely available in a form that has been named **Integrated Services Digital Network, or ISDN**. However, for reasons of cost (high), data rate (not very high), and installation difficulties, ISDN has not been widely accepted, and will likely be eclipsed by cheaper and/or faster data transmission alternatives.

ISDN services are available in a number of versions with various cable connection types and bit rates. We will briefly discuss the two forms are now readily available in most larger cities throughout the world. In particular, we will discuss the formats used in North America. **ISDN BRI (basic rate interface)** is available worldwide and offers a **192 kbps** digital service divided in a fashion that separates it into **one 16 kbps** signaling (call set-up, etc.) data streams and **two 64 kbps** data streams that can be used as two computer data streams, two digital phone streams, or one of each. The BRI service is often called the 2B+D service, indicating that two "B" channels and one "D" channel are available on a single connection.

Table 18.2: The North American Synchronous Optical Network (SONET) Hierarchy

North American Name	CCITT Name	Bit Rate
OC-1		51.84 Mbps
OC-3	STM-1	155.52 Mbps
OC-9	STM-3	466.56 Mbps
OC-12	STM-4	622.08 Mbps
OC-18	STM-6	933.12 Mbps
OC-24	STM-8	1244.16 Mbps
OC-36	STM-12	1866.24 Mbps
OC-48	STM-16	2488.32 Mbps

ISDN BRI services are delivered via the local-loop wiring that had been used before to simply

provide the analog telephone technology connection for your home and office phone.(Actually, not all existing telephone wiring is ``good enough" to support these data rates, and the PSTN company with whom one contracts for ISDN service will test the lines prior to selling the service.)

Once ISDN services have been purchased, users can connect a special interface box to their telephone wall plate for connection to computers, printers, telephones, and so forth. This device will support the call set-up function and allow users to enter (either on the front panel of the device or through a computer communications link and user interface software) the telephone number of another ISDN device anywhere in the PSTN. Thus, just as with analog telephone service, **many end points can be serviced from any one line.** In fact, the two B channels can be dialed into two different end points simultaneously.

Users who need higher speed direct data access with control signaling (to exploit switched circuit access) can purchase a T1 line to support the North American PRI (primary) service with 23B+D channels. That is, 23 64-kbps digital voice or data channels and 1 signaling channel.

Together, BRI and PRI ISDN services are now commonly called *Narrow Band ISDN*. **Faster Broadband ISDN** or B-ISDN services have been on the drawing boards for several years, and promise eventually to deliver SONET hierarchy switched digital data services to users. The ultimate goal of the telephone companies is to make B-ISDN the transport mechanism of choice for all data from bursty computer communications to continuous very high bandwidth television and future multimedia systems.

Next	Up	Previous	Index
----------------------	--------------------	--------------------------	-----------------------

Next: [18.3 The Packet-Switched Connection](#) **Up:** [18.2 Circuit-Based Networks](#) **Previous:** [18.2.3 An Example of Information Technology - Inside and Outside](#)

[Next](#) [Up](#) [Previous](#) [Index](#)

Next: [18.3.1 X.25 and the Virtual Circuit](#) **Up:** [18. Telephone and Data](#) **Previous:** [18.2.4 Integrated Services Digital Network](#)
Home: [Contents: Information Technology - Inside and Outside](#)

18.3 The Packet-Switched Connection

Early in the growth of point-of-sale terminals in large retail chains and ticket sale counters, a need became apparent that was dramatically different than that provided by permanent and switched circuits. What was needed was the ability to have hundreds, if not thousands, of terminals, spread across the country, send small, spaced streams of transaction data to central locations and to receive replies from those central locations, with rapid response time.

The solution came in the form of a new kind of data service known as a *packet-switched* delivery system. The components of this new system were:

- permanent circuits from the endpoint to a local PSTN switch office;
- the use of a packet interface protocol at the end points that transmits small packets of data encapsulated in a "data envelope" containing the address of the sender and desired recipient of the data;
- a packet "node" at the local PSTN office that receives these packets, determines the route to another packet node that would bring the packet closer to the destination, and stores the packet until space on a shared permanent circuit to the next node becomes available, at which time it is forwarded; and
- a small number of permanent circuits upon which the packets are transmitted among nodes.

In effect, a packet-switched network emulates the operation of the post office, except that packets of data rather than paper are stored and forwarded to destinations. As with the post office, great economy is obtained by concentrating the flow of traffic over well-defined and highly optimized routes. If a route becomes too busy over time, the PSTN can devote additional permanent circuit bandwidth (an additional line) to support the route. The users are charged on a per-packet basis, and obtain service with a speed that is generally much faster than that associated with circuit set-up, tear-down, and potential busy connection delays.

A key aspect of packet-switched networks is that many users share a packet channel. This is good from an economic point of view, but it also generates the possibility that the channel may become full if many users send data at the same time, delaying (or in some cases eliminating) the delivery of the packet.

-
- [18.3.1 X.25 and the Virtual Circuit](#)
 - [18.3.2 Wider Bandwidth Data Transmission: Frame Relay](#)
 - [18.3.3 Asynchronous Transfer Mode](#)

[Next](#) [Up](#) [Previous](#) [Index](#)

Next: [18.3.1 X.25 and the](#)**Up:** [18. Telephone and Data](#) **Previous:** [18.2.4 Integrated Services](#)
[Digital](#)*Information Technology - Inside and Outside*

[Next](#) [Up](#) [Previous](#) [Index](#)

Next: [18.3.2 Wider Bandwidth Data](#) **Up:** [18.3 The Packet-Switched Connection](#) **Previous:** [18.3 The Packet-Switched Connection](#) **Home:** [Contents: Information Technology - Inside and Outside](#)

18.3.1 X.25 and the Virtual Circuit

In 1976 the CCITT (International Consultative Committee on telegraphy and Telephony) announced the definition of a standard for packet-switched communications known as X.25. X.25 provided the packet-switched capability for multi point delivery of sporadic data as described above via an approach that has come to be known as a *virtual circuit*. A virtual circuit means that a path has been established (via some type of call set-up) between end points, but that path may not be uniquely dedicated to those users.

An X.25 service network provides a standard digital interface between a computer (or other digital device, such as a sales terminal) and a single PSTN node. However, at any given moment, the source endpoint could direct data to one or more destination end points without the need for call set-up and tear-down before changing end points. Instead, several "virtual circuits" could be established simultaneously by call set-up with several destinations. Then a small "address" is affixed to each message to indicate to the X.25 network nodes which of the destinations previously selected is to receive the data.

A user's cost in using X.25 is determined both by the connection time of all virtual circuits, and by the amount of data transmitted to each of those destinations. This reflects the costs to the PSTN both of keeping the lines open and of handling the data.

A number of new X.25 based network systems arose that were not outgrowths of the telephone industry in response to the popularity of the X.25 virtual circuit packet service. These companies are often referred to collectively as the Public Data Networks (PDN).

The maximum data rate available via X.25 services at this time is about 64 kbps. The reasons for this maximum rate and means to go beyond it in a packet-switched network are treated in the following section on Frame Relay.

[Next](#) [Up](#) [Previous](#) [Index](#)

Next: [18.3.2 Wider Bandwidth Data](#) **Up:** [18.3 The Packet-Switched Connection](#) **Previous:** [18.3 The Packet-Switched Connection](#) *Information Technology - Inside and Outside*

[Next](#) [Up](#) [Previous](#) [Index](#)

Next: [18.3.3 Asynchronous Transfer Mode](#) **Up:** [18.3 The Packet-Switched Connection](#) **Previous:** [18.3.1 X.25 and the](#) **Home:** [Contents: Information Technology - Inside and Outside](#)

18.3.2 Wider Bandwidth Data Transmission: Frame Relay

A relatively new entrant in the virtual circuit packet network market is the [Frame Relay service](#). The distinguishing characteristic of Frame Relay is that, unlike in the X.25 service, [there is no guarantee that a packet once sent will be delivered](#). Now this would appear to be a relatively useless service at first. However, [the guarantees provided by X.25 result in low speed and high cost!](#) Frame Relay services allow the end-users to apply their own strategies for replacing lost data and throttling data usage so as to make effective use of the service. In return, [Frame Relay provides up to 2 Mbps data rates at lower costs than X.25 for moving data in virtual circuits](#).

[The higher speed and lower cost associated with Frame Relay derives from the fact that in an X.25 circuit, a great deal of processing must take place at every node in the network](#). Hence, high-speed computers must be employed at each node. In turn, the amount of data that can be handled is driven by the availability, or lack thereof, of this computational power. [A Frame Relay data packet is simply passed on to the correct connection if received from the previous one. A "dumb" piece of fast, cheap, dedicated, easily duplicated hardware can handle this transaction.](#)

[Next](#) [Up](#) [Previous](#) [Index](#)

Next: [18.3.3 Asynchronous Transfer Mode](#) **Up:** [18.3 The Packet-Switched Connection](#) **Previous:** [18.3.1 X.25 and the](#) *Information Technology - Inside and Outside*

[Next](#) [Up](#) [Previous](#) [Index](#)

Next: [Summary](#) **Up:** [18.3 The Packet-Switched Connection](#) **Previous:** [18.3.2 Wider Bandwidth Data](#)
Home: [Contents: Information Technology - Inside and Outside](#)

18.3.3 Asynchronous Transfer Mode

The highest practical rate for Frame Relay, approximately 2 Mbps, is quite fast compared to X.25, but is small compared to the speeds achievable on dedicated permanent circuits today. Furthermore, this is too slow for the transmission of multimedia data, such as might be generated by on-demand movie delivery services and interactive high definition TV. We have seen in the progression from X.25 to Frame Relay that the key to moving packet-switched data more quickly is simplification of the data handling at the network nodes. This is taken to the extreme in the most recent packet-switched offerings from the PSTN companies: ATM (Asynchronous Transfer Mode).

ATM further squeezes overhead out of the process of handling data streams by making the following additional concession: every packet (now called a cell) is of fixed size--53 bytes--with 48 bytes devoted to data and the remainder to addressing and controlling the virtual circuit.

By breaking the data into small cells it becomes possible to pack those cells into standardized cell-divided data streams, "on-the-fly." Furthermore, the small cell size leads to a lessening of the storage needed in the store-and-forward architecture of the network. As in Frame Relay, we also abandon any guarantees of packet delivery and let the end-users apply their own techniques to recover from missing cells.

ATM-based virtual circuit packet transmission services for speeds up to OC-3 SONET, 155 Mbps, are readily available from [PSTN companies](#). ATM equipment is [now commercially available](#) that handles data at speeds associated with the OC-12 SONET system, 622 Mbps. And, [new integrated circuit chips](#) have also been previewed that handle ATM data rates up to OC-96 SONET speeds of 5Gbps.

[Next](#) [Up](#) [Previous](#) [Index](#)

Next: [Summary](#) **Up:** [18.3 The Packet-Switched Connection](#) **Previous:** [18.3.2 Wider Bandwidth Data](#)
[Information Technology - Inside and Outside](#)

[Next](#) [Up](#) [Previous](#) [Index](#)

Next: [Try These Exercises](#) **Up:** [18. Telephone and Data](#) **Previous:** [18.3.3 Asynchronous Transfer Mode](#) **Home:** [Contents: Information Technology - Inside and Outside](#)

Summary

Communications networks can be characterized in several different ways including: speed, type of transmission (analog vs. digital), one-directional or bidirectional, physical arrangement of facilities, means of getting information to the correct location, and intended uses. Fortunately, as the number of different uses for communications networks explodes, it has *not* been necessary to design and build special-purpose networks for each use. The most fundamental characteristic of networks is their configuration as either *circuit-based* or *packet-based*, as described in this chapter. But this distinction is blurred by the use of circuit switched connections in the implementation of packet-based networks and the creation of virtual circuits through packet-based networks.

Another distinction, that between analog and digital information, has almost completely disappeared, as essentially all communications networks are digital with conversions to and from analog as needed.

Finally, it is important to note that the type of network is not defined by the physical facilities (wire, optical fiber, radio transmission) that actually carry the data. A given transmission facility may simultaneously carry some packet-switched data and some circuit-switched data. The equipment (routers, switches, etc.) in the communications hub sorts everything out appropriately. Hence, as we move from a predominance of telephone-generated data to other forms of data sources, it will not be necessary to discard all the long-distance transmission facilities already in place.

[Next](#) [Up](#) [Previous](#) [Index](#)

Next: [Try These Exercises](#) **Up:** [18. Telephone and Data](#) **Previous:** [18.3.3 Asynchronous Transfer Mode](#) [Information Technology - Inside and Outside](#)

Next: [19. The Local Area](#) **Up:** [18. Telephone and Data](#) **Previous:** [Summary](#) **Home:** [Contents: Information Technology - Inside and Outside](#)

Try These Exercises

1.

Examine the list of characteristics given at the beginning of the chapter for telephone and cable networks. Develop a similar list for the Internet, based upon your Web viewing experience.

2.

Your company works with customers to produce t-shirts with custom-designed graphics. This requires you to communicate with the customers regarding details of their order (number of shirts, sizes, means of payment, etc.) as well as the graphic design. Then you must transmit the graphic and associated information digitally to the plant (you work with only one plant) that actually manufactures the t-shirts. Assume that you have 50 customers to deal with each day, at various stages in the process. Describe the data communications needs, being as specific as possible, with regard to circuit or packet switching, and so forth.

3.

Design a packet-switched system, considering the following parameters: packet size (number of bytes per packet), necessary address information on each packet, and virtual circuit set-up information (specific information to set up each virtual circuit). Assume that the terminals are used for surfing the Web, with 50% of the requests representing graphical information.

4.

Pretend you are Alexander Graham Bell and design the first telephone network for a city of 10,000 households. Assume that each household has one phone line, and calls only within the city, placing four calls per day. Assume that each call lasts 10 minutes.

5.

For your professional area, identify a data transmission need, and comment on the applicability of packet-switched versus circuit-switched methods for handling that data.

6.

Assume that 10 terminals are generating packets of data, each at a rate of 100 packets per second, and that the packets are 100 bits in length. All of these terminals are connected to a router which has a single data connection to the Internet. What minimum data rate would be required on the Internet connection? Would this minimum data rate be acceptable in practice? Explain.

7.

Continuing from the above question, assume that the average packet rate is as given above, but that the rate is not constant. Assume that the rate can vary from 0 to 1,000 packets per second from each terminal. Now what data rate is required from the router to accommodate all of the

packets in the worst case? Given that the average data rate from the terminals has not changed, how much of the capacity of the new line will be unused, on average? Is there a way (with some extra equipment in the router) to transmit all of the packets with a line of capacity smaller than that just calculated, but larger than the minimum from the previous question? Explain.

[Next](#) [Up](#) [Previous](#) [Index](#)

Next: [19. The Local Area](#) **Up:** [18. Telephone and Data](#) **Previous:** [Summary](#) *Information Technology - Inside and Outside*